

Tous droits strictement réservés. Reproduction ou communication a des tiers interdite sous quelque forme que ce soit sans autorisation écrite du propriétaire. Propriété de c FCI. Droits de reproduction FCI.

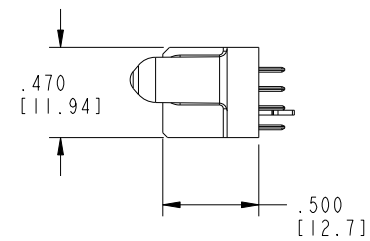

All rights strictly reserved. Reproduction or issue to third parties in any form whatever is not permitted without written authority from the proprietor. Property of FCI. Copyright FCI.

PRODUCT NO. 51751-005 NOTE: ③	ROWS DCBA	POWER					SIGNAL				E1	
		E2	P5	P4	P3	P2	P1	4	3	2		1

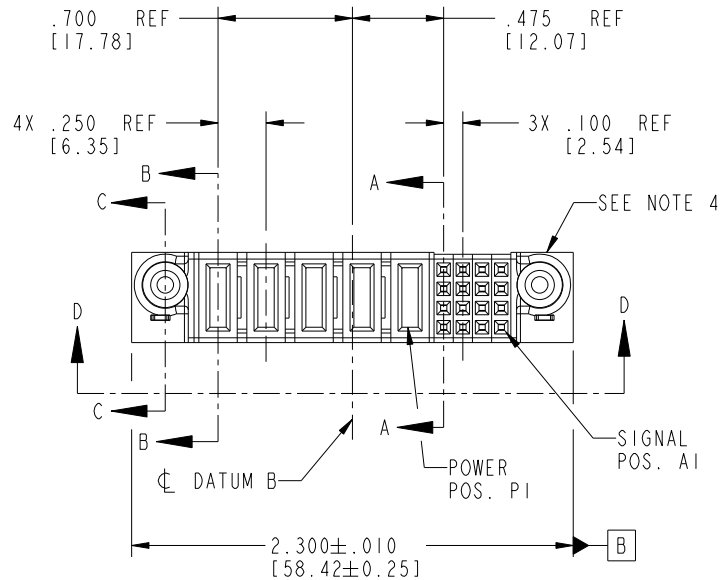

CODE	DIM "M" MATING LENGTH	CONTACT TYPE
E	N/A [N/A]	SIGNAL
PA	.042 [1.07]	POWER
PD	.092 [2.34]	POWER
HA	N/A [N/A]	HOLD-DOWN

mat'l code				SEE NOTE 2		tolerances unless otherwise specified		CUSTOMER		 www.fciconnect.com	
lfr	ecn no.	dr	date	linear	.XX±.01/0.X±0.3		COPY		 title 16S + 5P VERTICAL SOLDER RECEPTACLE		
A	V20636	JWS	04-01-02		.XXX±.005/0.XX±0.13		projection				
B	DG05-0192	SJ	06/24/05	angles	.XXX±.0020/0.XXX±0.051		 INCH/MM		product family PwrBlade code 213		
C	DG06-0381	HEAVEN	09/12/06		0°±2°		scale 1:1		size dwg no A 51751-005 sheet 1 of 4		
D	DG08-0251	W D	09/13/08	dr	J. SHAFFER	04-01-02					
				enrg	J. ALLISON	04-01-02					
				chr	J. ALLISON	04-01-02					
				appd	J. ALLISON	04-01-02					
sheet index	revision sheet	D 1	D 2	D 3	D 4						

Pro/E

PDM: Rev: D

STATUS: Released

Printed: Sep 20, 2008

cage code 22536

Tous droits strictement réservés. Reproduction ou communication a des tiers interdite sous quelque forme que ce soit sans autorisation écrite du propriétaire. Propriété de c FCI. Droits de reproduction FCI.

All rights strictly reserved. Reproduction or issue to third parties in any form whatever is not permitted without written authority from the proprietor. Property of FCI. Copyright FCI.



PRODUCT NUMBER

51751-005--

NOTE: ③

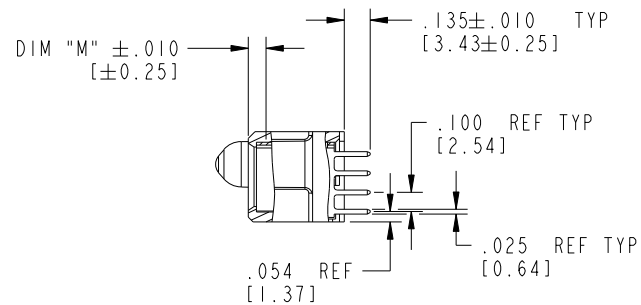
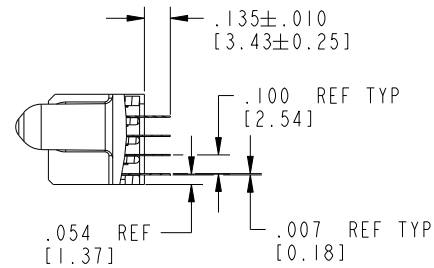
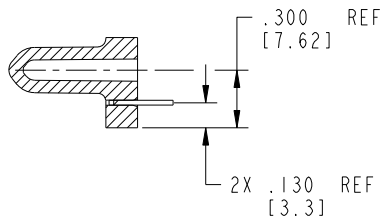
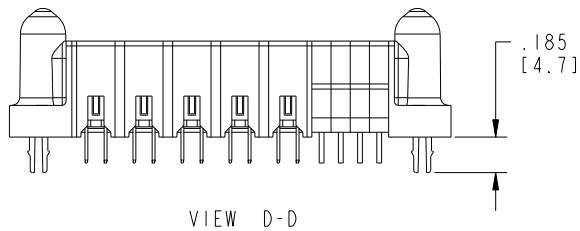

mat'l code		SEE NOTE 2		tolerances unless otherwise specified		CUSTOMER		FCI	
ltr	ecn no.	dr	date	linear	.XX±.01/0.X±0.3	projection	www.fciconnect.com		
D					.XXY±.005/0.XX±0.13	INCH/MM	title 16S + 5P		
				angles	.XXX±.002/0.XXX±0.051	scale	VERTICAL SOLDER RECEPTACLE		
				dr	0°±2°	1:1	product family PwrBlade		code
				engr	J. SHAFFER 04-01-02		size	dwg no	213
				chr	J. ALLISON 04-01-02		A 51751-005		sheet
				appd	J. ALLISON 04-01-02				2
sheet index	revision sheet								

Pro/E

PDM: Rev: D

STATUS: Released

Printed: Sep 20, 2008

Tous droits strictement réservés. Reproduction ou communication a des tiers interdite sous quelque forme que ce soit sans autorisation écrite du propriétaire. Propriété de c FCI. Droits de reproduction FCI.



All rights strictly reserved. Reproduction or issue to third parties in any form whatever is not permitted without written authority from the proprietor. Property of FCI. Copyright FCI.

PRODUCT NUMBER  
51751-005--  
NOTE: ③

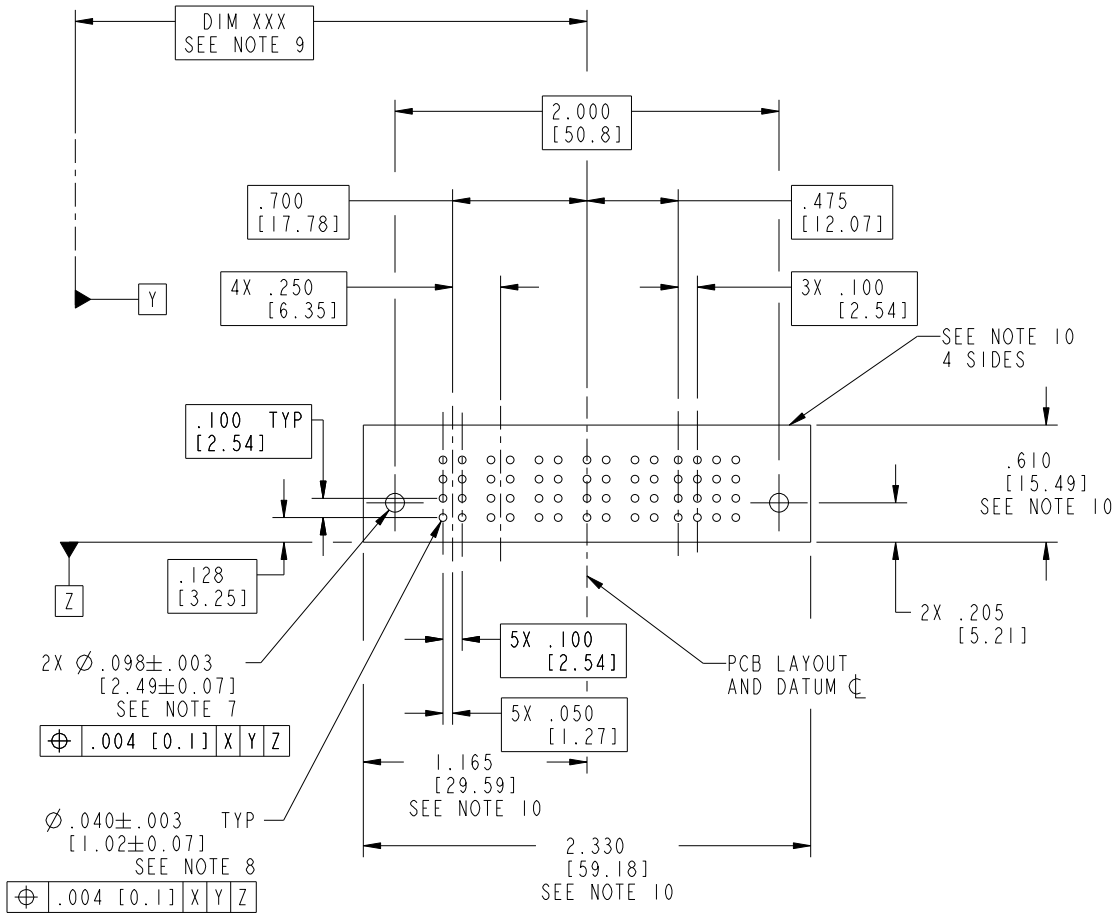

RECOMMENDED PCB LAYOUT

mat'l code		SEE NOTE 2		tolerances unless otherwise specified		CUSTOMER		FCI	
lfr	ecn no.	dr	date	linear	.XX±.01/0.X±0.3	COPY		www.fciconnect.com	
D				angles	.XXX±.005/0.XX±0.13 .XXX±.0020/0.XXX±0.051	projection		title 16S + 5P VERTICAL SOLDER RECEPTACLE	
				dr	J. SHAFFER 04-01-02	INCH/MM		product family PwrBlade code 213	
				enrg	J. ALLISON 04-01-02	scale 1:1		size dwg no 51751-005 sheet 3	
				chr	J. ALLISON 04-01-02				
				appd	J. ALLISON 04-01-02				
sheet index	revision sheet								

cage code 22526

Pro/E

PDM: Rev: D

STATUS: Released

Printed: Sep 20, 2008



PRODUCT NUMBER  
51751-005--  
NOTE: ③

NOTES:

1. DIMENSIONS AND TOLERANCES ARE IN ACCORDANCE WITH ASME Y14.5M, 1994 UNLESS OTHERWISE SPECIFIED.

CONNECTOR NOTES:

② HOUSING MATERIAL: UL 94 V-0 GLASS FILLED HIGH-TEMP THERMOPLASTIC  
POWER CONTACT MATERIAL: COPPER ALLOY  
SIGNAL PIN MATERIAL: COPPER ALLOY

ⓓ③ SEE ITEM 5 & 6 IN PRINT 10064183 FOR PLATING SPEC OF 51751-005 AND 51751-005LF RESPECTIVELY.

④ MANUFACTURER'S NAME, P/N, AND DATE CODE TO APPEAR ON THIS SURFACE.

5. PRODUCT SPECIFICATION GS-12-149.  
APPLICATION SPECIFICATION BUS-20-067.

PCB - NOTES:

6. ALL HOLE DIAMETERS ARE FINISHED HOLE SIZE.

⑦ MOUNTING HOLES, WHERE APPLICABLE, ARE UNPLATED.

⑧  $\varnothing .0453 \pm 0.0010$  [ $1.151 \pm 0.025$ ] DRILLED HOLES PLATED WITH  $0.0003$  [ $0.008$ ] MIN SnPb OR Sn OVER  $.001$  [ $0.03$ ] TO  $.003$  [ $0.08$ ] Cu PLATING TO ACHIEVE  $\varnothing .040 \pm .003$  [ $1.02 \pm .07$ ] HOLE.

9. "DIM XXX" TO BE DETERMINED BY THE CUSTOMER.

10. CONNECTOR KEEP-OUT ZONE.

11. ⓓ SYMBOL WILL BE NEXT TO ANY DIMENSION, VIEW, OR NOTE WHICH HAS BEEN MODIFIED WITH THE CURRENT DRAWING REVISION.

mat'l code		SEE NOTE 2		tolerances unless otherwise specified		CUSTOMER		FCI		www.fciconnect.com	
ltr	ecn no.	dr	date	linear	.XX±.01/0.X±0.3	COPY		title		16S + 5P	
D				projection	.XXY±.005/0.XX±0.13	⊕		VERTICAL SOLDER RECEPTACLE		code	
				angles	.XXX±.0020/0.XXX±0.051	INCH/MM		product family		213	
				dr	0° ± 2°	1:1		PwrBlade		sheet	
				enrg	J. SHAFFER 04-01-02			size		4	
				chr	J. ALLISON 04-01-02			A		51751-005	
				appd	J. ALLISON 04-01-02						
sheet index	revision sheet										